

Stainless Steel-Locking pins

with axial lock (magnetic)

SPECIFICATION

Pin
Stainless Steel AISI 303

Knob
Plastic Technopolymer (Polyamide PA)

- black-grey
- temperature resistant up to 80 °C

Retaining magnet
Neodymium, iron, boron

INFORMATION

GN 124.1 Stainless Steel-Locking pins are used for quickly fixing, connecting and locking various parts and workpieces made of magnetic materials.

A neodymium magnet is recessed into the underside of the bolt and axially retains the bolt in its inserted position. High-quality surfaces with perpendicular locating holes promote magnetic flux to produce excellent axial retention.

The rated shear stresses of the bolt cross-section are theoretical guide values only and do not constitute any warranty. They constitute no general warranty of quality and condition. The user must determine from case to case whether a product is suitable for the intended use.

- Range of locking pins (see page 868)

ACCESSORY

- Ball chains GN 111 (see page 904)
- Stainless Steel-Ball chains GN 111.5 (see page 905)
- Retaining cables GN 111.2 (see page 906)
- Spiral retaining cables GN 111.4 (see page 908)

TECHNICAL INFORMATION

- Stainless Steel characteristics (see page A26)
- Plastic characteristics (see page A2)



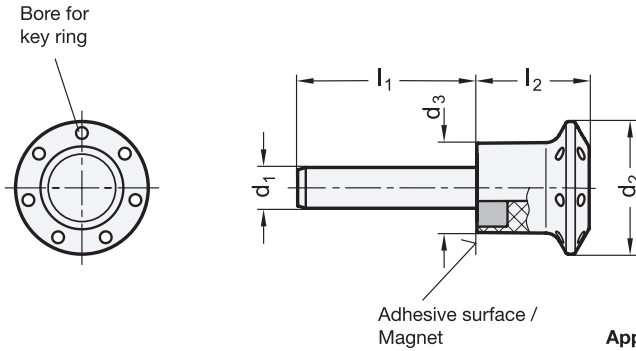

Application example

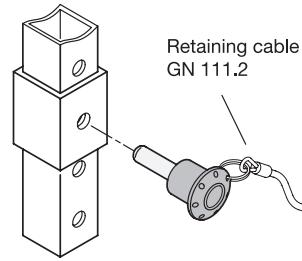

GN 124.1

STAINLESS STEEL

Description	d1 -0.04/-0.08	l1	d2	d3	l2	Locating bore	Axial holding force in N ≈	Load in kN ≈ (Double sided shear force) according DIN 50141	⚖️
GN 124.1-6-12	6	12	26	17.5	22	6	65	22	13
GN 124.1-6-17	6	17	26	17.5	22	6	65	22	19
GN 124.1-6-22	6	22	26	17.5	22	6	65	22	20
GN 124.1-6-27	6	27	26	17.5	22	6	65	22	21
GN 124.1-6-32	6	32	26	17.5	22	6	65	22	22
GN 124.1-6-42	6	42	26	17.5	22	6	65	22	24
GN 124.1-6-52	6	52	26	17.5	22	6	65	22	27
GN 124.1-8-17	8	17	26	17.5	22	8	45	40	24
GN 124.1-8-22	8	22	26	17.5	22	8	45	40	24
GN 124.1-8-27	8	27	26	17.5	22	8	45	40	25
GN 124.1-8-32	8	32	26	17.5	22	8	45	40	27
GN 124.1-8-42	8	42	26	17.5	22	8	45	40	31
GN 124.1-8-52	8	52	26	17.5	22	8	45	40	35
GN 124.1-8-62	8	62	26	17.5	22	8	45	40	38
GN 124.1-10-18	10	18	34	23	28.5	10	95	62	43
GN 124.1-10-23	10	23	34	23	28.5	10	95	62	46
GN 124.1-10-28	10	28	34	23	28.5	10	95	62	49
GN 124.1-10-33	10	33	34	23	28.5	10	95	62	52
GN 124.1-10-43	10	43	34	23	28.5	10	95	62	58
GN 124.1-10-53	10	53	34	23	28.5	10	95	62	64
GN 124.1-10-63	10	63	34	23	28.5	10	95	62	71
GN 124.1-12-23	12	23	34	23	28.5	12	75	90	52
GN 124.1-12-33	12	33	34	23	28.5	12	75	90	61
GN 124.1-12-43	12	43	34	23	28.5	12	75	90	70
GN 124.1-12-53	12	53	34	23	28.5	12	75	90	78
GN 124.1-12-63	12	63	34	23	28.5	12	75	90	87
GN 124.1-12-83	12	83	34	23	28.5	12	75	90	104



8

Indexing elements