

GN 430.1

Ledge handles
with lettering block

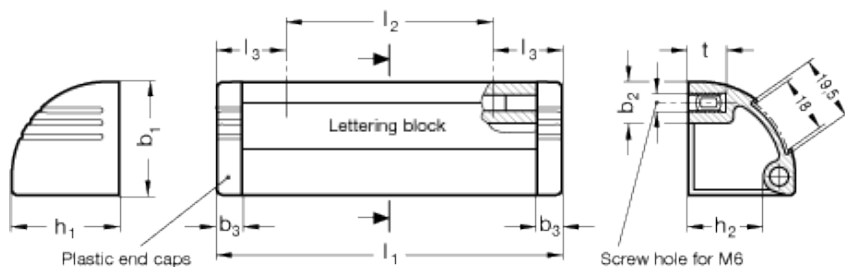

technical informations

Aluminium tube

- Version SW: RAL 9005 black, matte finish, epoxy resin coating.
- Version EL: anodised, natural colour, matte finish.

Side end caps

Polyamide based (PA) technopolymer, black grey colour.

Lettering block

Insert groove supplied with:

- Paper strip 200g/m² bright white, age-resistant
- transparent PVH hard film
- The paper strip can also be used as substrate for common lettering tape in widths below 18 mm.
- Go to www.elesa-ganter-griff.com/downloads to open a Word document which you can use to create lettering and labels.

Accessories on request (For sufficient quantities)

- single paper.
- film strips.

Features and applications

Typical applications for ledge handles with lettering block GN 430.1 include swivel or sliding doors on protective doors and equipment. They are also suitable for use as drawer handles.

The screw channel for screw sizes M6 (extruded aluminium) allows an optional number of fixing screws in any position within the dimension l_2 .

Special lengths are easily realised because the ledge handle needs no further machining when mounted.

In the design with lettering block, the end cap when delivered is mounted on one side such that the paper / film strip supplied can be lettered and pushed into the groove provided.

The paper strip can also be used as substrate for common lettering tape in widths below 18 mm. Go to www.ganter-griff.de/service to open a ZIP-file with different documents (Word®, Open Office, PDF) which you can use to create lettering and labels.

Single paper / film strips available on request.

Assembly instructions (for every screw coupling)

- Maximum load: 400 N.
- Maximum tightening torque: 4 Nm.
- Minimum screw-in depth: 10 mm.

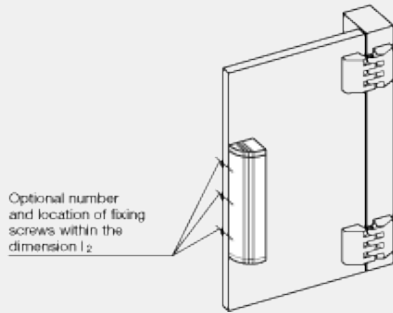

Standard Elements	Main dimensions							Mounting holes		Weight
	Description	l_1	b_1	b_3	h_1	h_2	l_2	l_3	b_2	
GN 430.1-110-SW	110	36	8	34	24	66	22	13	12	87
GN 430.1-110-EL	110	36	8	34	24	66	22	13	12	100
GN 430.1-130-SW	130	36	8	34	24	86	22	13	12	101
GN 430.1-130-EL	130	36	8	34	24	86	22	13	12	130
GN 430.1-150-SW	150	36	8	34	24	106	22	13	12	140
GN 430.1-150-EL	150	36	8	34	24	106	22	13	12	117
GN 430.1-200-SW	200	36	8	34	24	156	22	13	12	175
GN 430.1-200-EL	200	36	8	34	24	156	22	13	12	120
GN 430.1-250-SW	250	36	8	34	24	206	22	13	12	27
GN 430.1-250-EL	250	36	8	34	24	206	22	13	12	240
GN 430.1-300-SW	300	36	8	34	24	256	22	13	12	178
GN 430.1-300-EL	300	36	8	34	24	256	22	13	12	240
GN 430.1-400-SW	400	36	8	34	24	356	22	13	12	320
GN 430.1-400-EL	400	36	8	34	24	356	22	13	12	408
GN 430.1-500-SW	500	36	8	34	24	456	22	13	12	400
GN 430.1-500-EL	500	36	8	34	24	456	22	13	12	380

